

# High-end Laser Systems for Photolithography

Harald Rossmeier (TOPTICA Photonics SE) @ OPTIMAL M36 Workshop

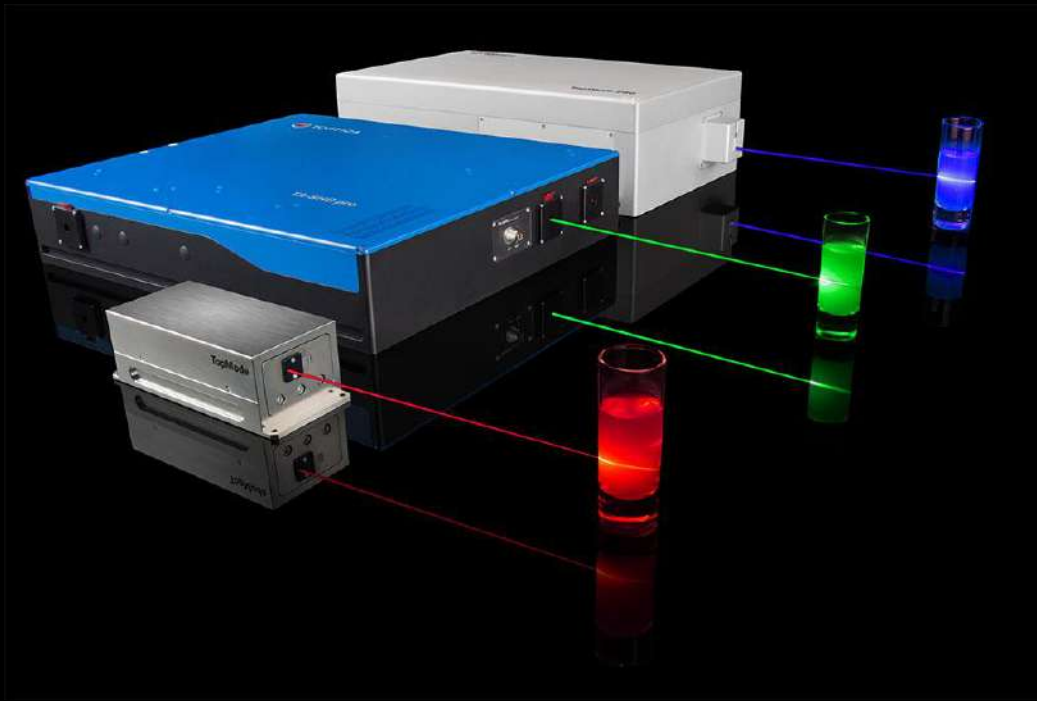

# Agenda

1. **TOPTICA – short introduction**
2. Photolithography
3. Laser solutions for maskless lithography
  - Overview
  - Example TopWave 405
4. Sustainability aspects

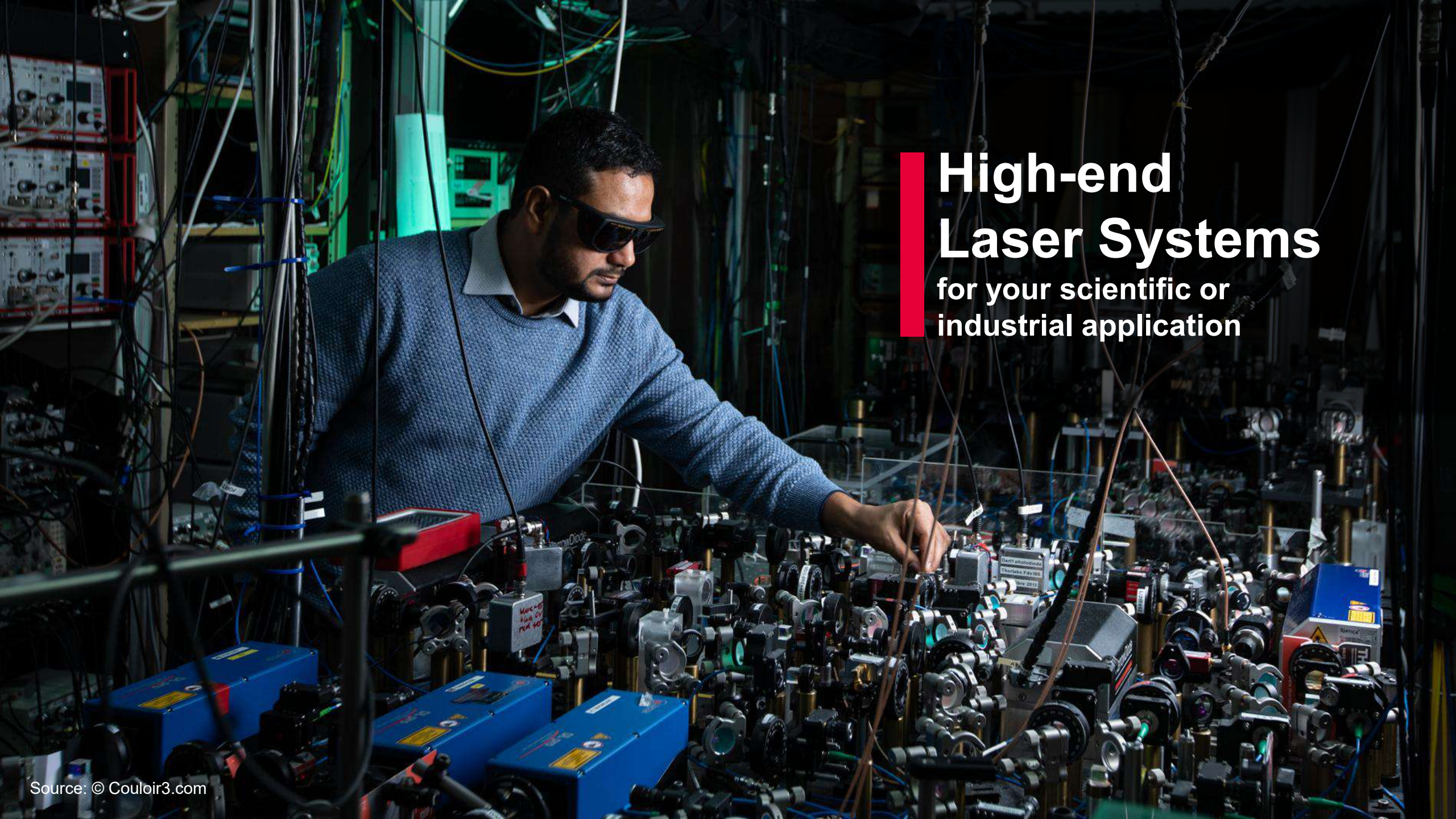

# High-end Laser Systems

for your scientific or  
industrial application



**all wavelengths.**

190 nm – 0.1 THz

# Our Product Range at a Glance

## Biophotonics & Microscopy



 Single Mode Diode Lasers



 ps/fs Fiber Lasers



 Multi Laser Engines

## Measurement & Processing



 Single Frequency Diode Lasers



 Terahertz Systems



 Wavelength Meters & Laser Diodes

## Quantum Technologies

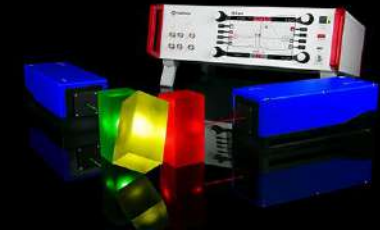

 Tunable Diode Lasers



 CW Fiber Lasers

 Frequency Combs



 Laser Rack Systems

# TOPTICA – Markets & Business units

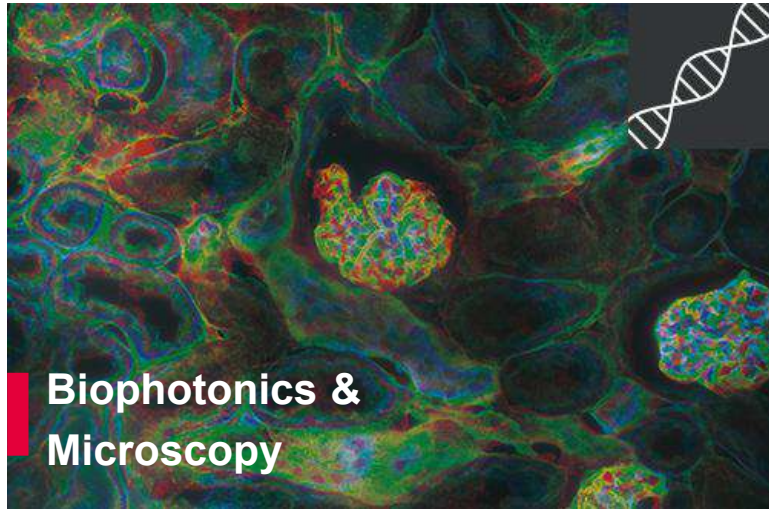

## Biophotonics & Microscopy

Microscopy  
Neuroscience  
Cytometry

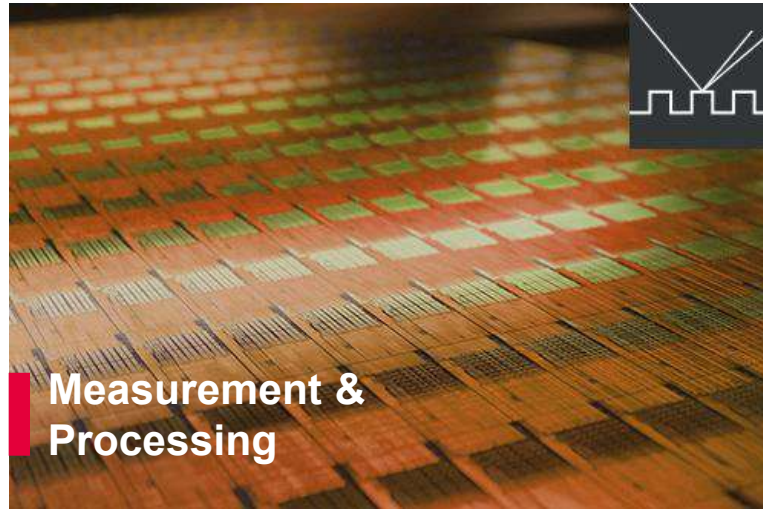

## Measurement & Processing

Lithography & Holography  
Spectroscopy & Inspection  
Metrology



## Quantum Technologies & Spectroscopy

Quantum Computing & Simulation  
Quantum Sensing & Atomic Clocks  
Quantum Communication

# TOPTICA Group: Key Figures



- TOPTICA Photonics  
Germany, USA, Japan, China, France
- TOPTICA Projects  
Germany
- TOPTICA eagleyard  
Germany
- TOPTICA Photonics Distributors

## Key Figures

Founded	1998
Employees	600
Headquarters	Gräfelfing (Munich) Germany

## Technology

Diode Laser Systems	190 – 4000 nm
Ultrafast ps/fs Fiber Lasers	390 – 15000 nm
Terahertz Generation	0.1 – 6 THz
High Power Laser Diodes	630 – 1120 nm (TOPTICA eagleyard)



# Agenda

1. TOPTICA – short introduction
- 2. Photolithography**
3. Laser solutions for maskless lithography
  - Overview
  - Example TopWave 405
4. Sustainability aspects

# Photolithography

- **Patterning process** used in semiconductor manufacturing where light transfers circuit designs onto a photoresist-coated wafer, enabling the **creation of micro- and nanoscale features**
- **Rayleigh criterion equation**

$$CD = k_1 \cdot \frac{\lambda}{NA}$$

- **Continuous drive towards**

- **lower wavelengths**
- **higher NA**

**to achieve smallest possible feature size**

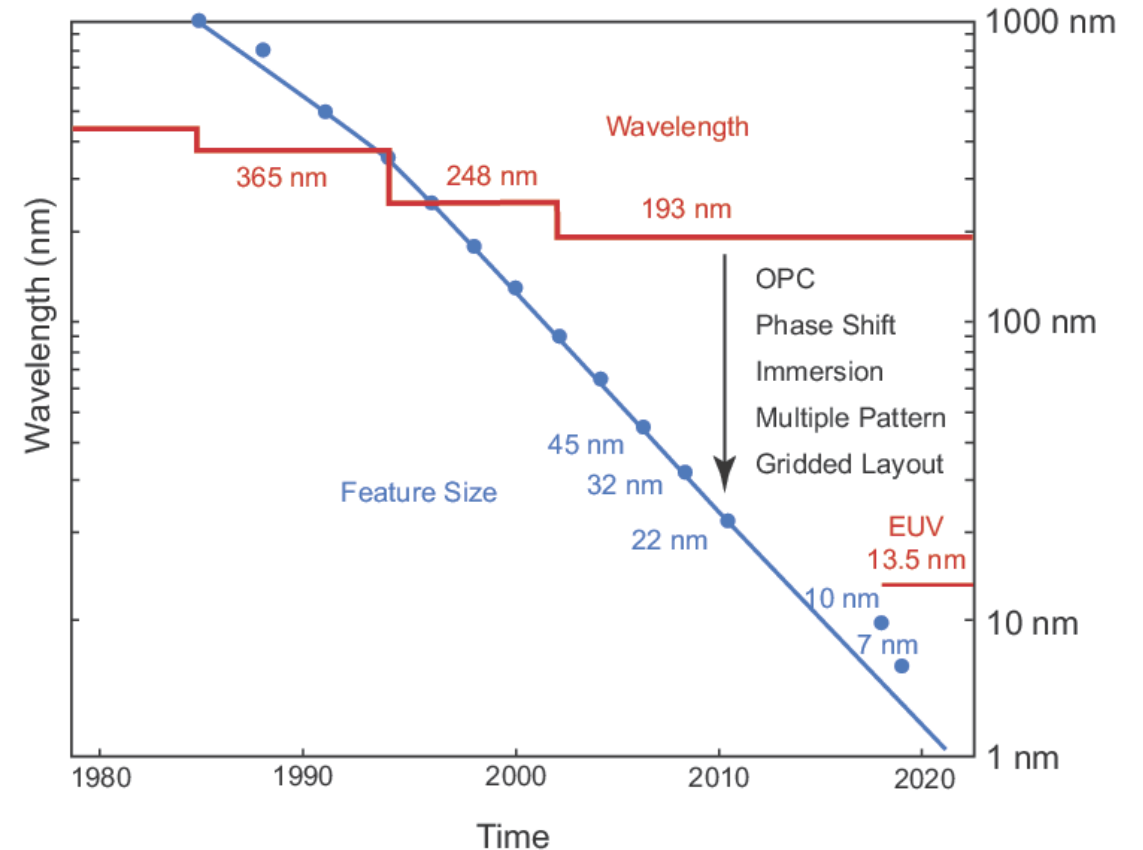

# Types of photolithography

## With photomask

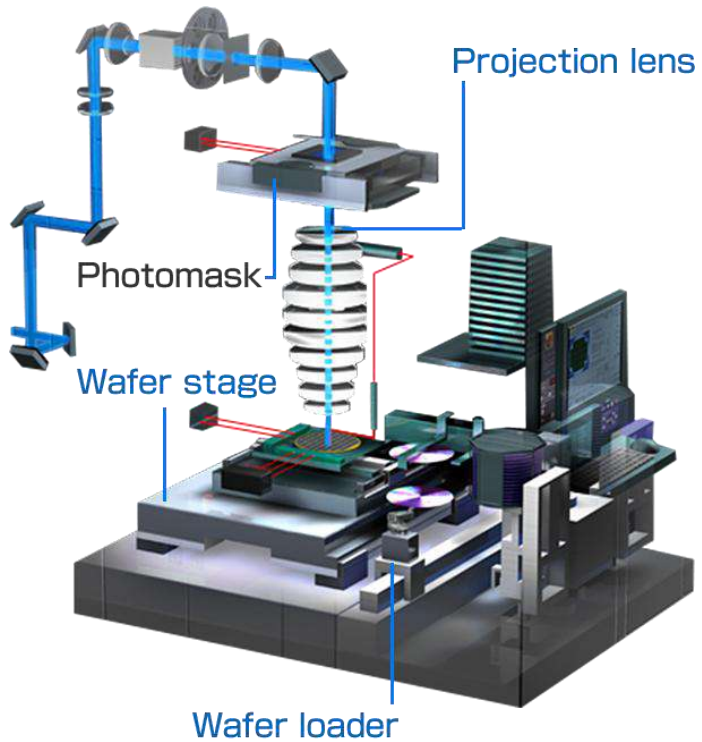

## Maskless

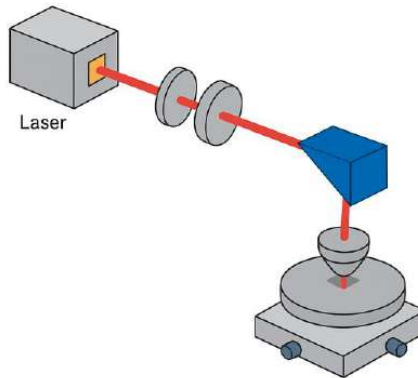

**Direct Writing**

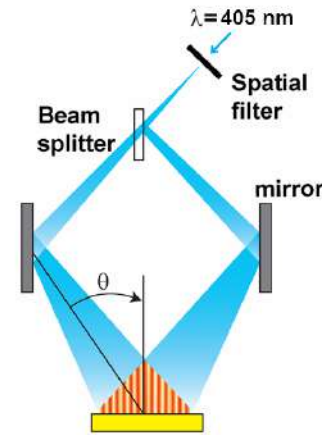

**Interference lithography**

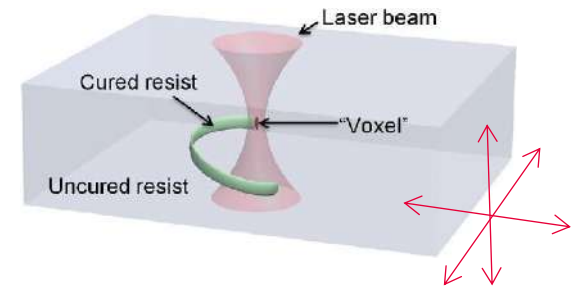

**2-photon lithography**

# ■ TOPTICA laser solutions support maskless lithography

## Focus on maskless lithography

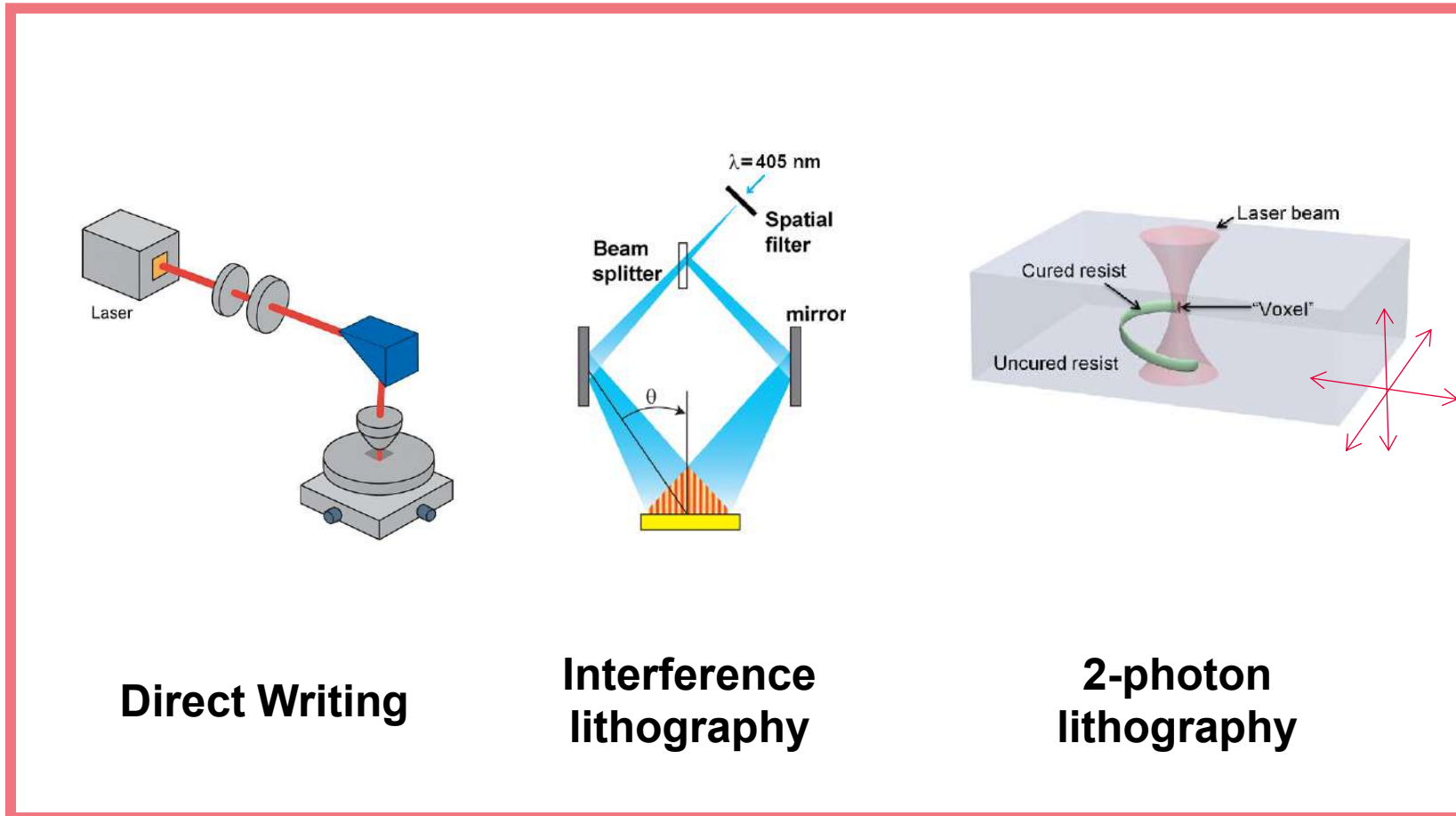

# Agenda

1. TOPTICA – short introduction
2. Photolithography
- 3. Laser solutions for maskless lithography**
  - Overview
  - Example TopWave 405
4. Sustainability aspects

# Lasers requirements for of maskless lithography

## Continuous wave (CW)

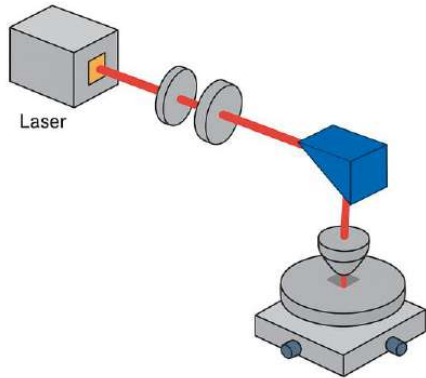

Direct Writing

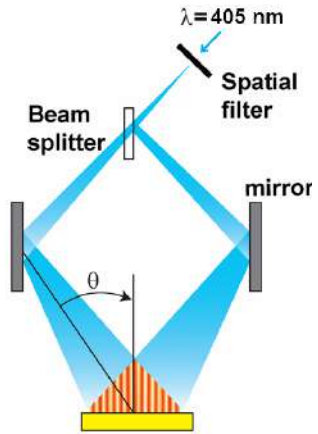

Interference lithography

## Ultrafast pulsed lasers

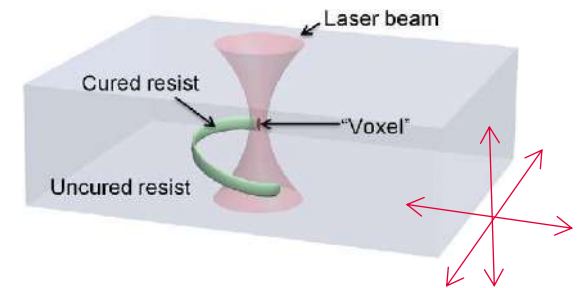

2-photon lithography

# Key laser requirements for 2-photon lithography

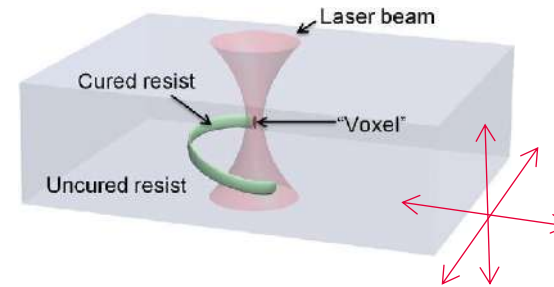
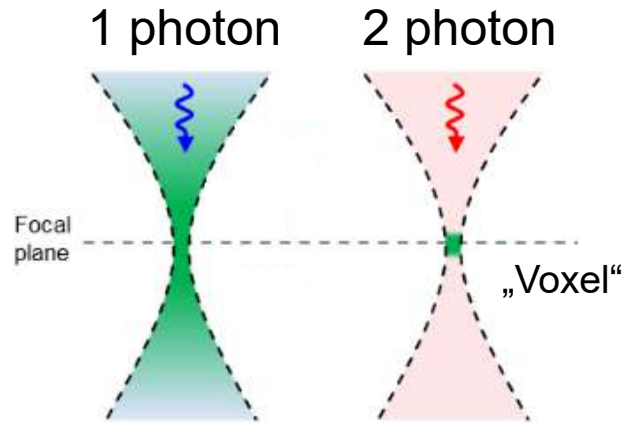

Requirement	Benefit
Optimized energy deposition	Cure, but not "evaporate"
High beam quality	Small feature size
Matching wavelength	Use of existing photoresist
Dispersion compensation	Shortest pulse at imaging plane
Power modulation capability	Greyscale and blanking
High Pointing stability	Fine scale resolution
Matching wavelength	Use of existing photoresist

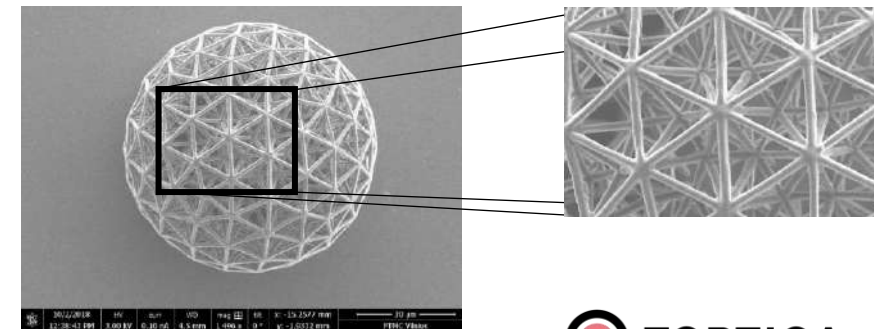

Source: Workshop of Photonics, Lithuania

## 2-photon - Solutions Overview



Specification	FemtoFiber smart 780	FemtoFiber ultra 780
Type	Passive mode-locked Erbium fiber oscillator	Passive mode-locked Erbium fiber oscillator
Wavelength <sup>1)</sup>	783 nm	780
Output Power	> 120 mW	> 1 W (HP version > 1.5W)
Pulse duration	< 100 fs	< 150 fs (HP version < 170 fs)
Rep. rate	80 MHz	80 MHz
Beam quality	$M^2 < 1.2$	$M^2 < 1.2$
Special	<ul style="list-style-type: none"> <li>Polarization-maintaining fibers only</li> <li>Very compact design, all-in-one box (all electronics inside)</li> </ul>	<ul style="list-style-type: none"> <li>Polarization-maintaining fibers only</li> <li>GDD adjustment included (-30.000 fs<sup>2</sup> ... 0 fs<sup>2</sup>)</li> <li>AOM integration optional, for fast power control and modulations up to MHz speed</li> </ul>

<sup>1)</sup> Further wavelengths (incl. SHG) and power levels on request, e.g. 525 nm / 1 W

# Key laser requirements for maskless (1-photon) lithography

Requirement	Benefit
Short wavelength	Small feature size
Diffraction limited beam quality	Small feature size
High power	Throughput
Narrow linewidth	Avoids angular dispersion in acousto-optic elements
Ease of use, high reliability	Low CoO

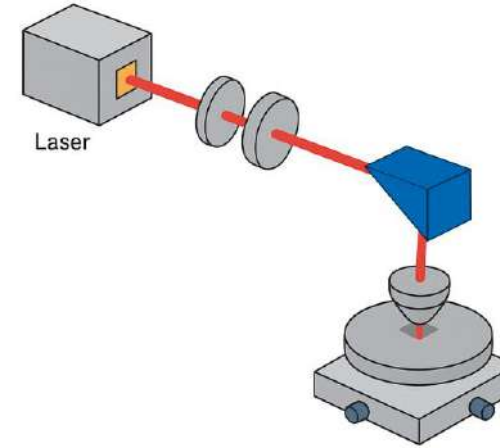

Specific for interference lithography	
High coherence length	Stable and high contrast interference pattern

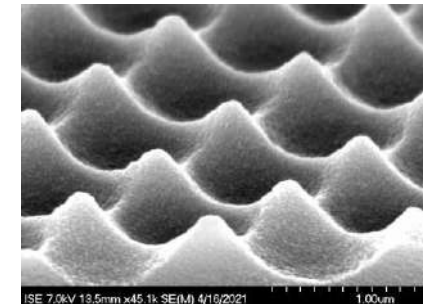
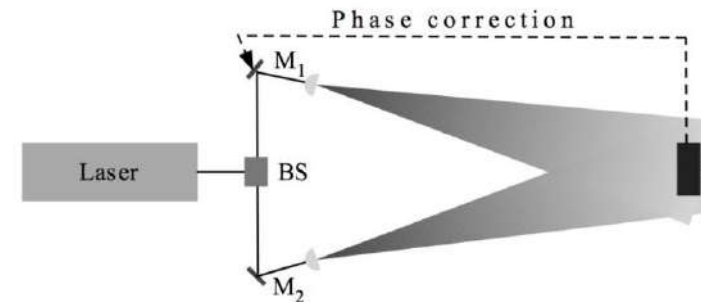

Source: Fh. ISE

# 1-photon – TOPTICA Laser Solutions

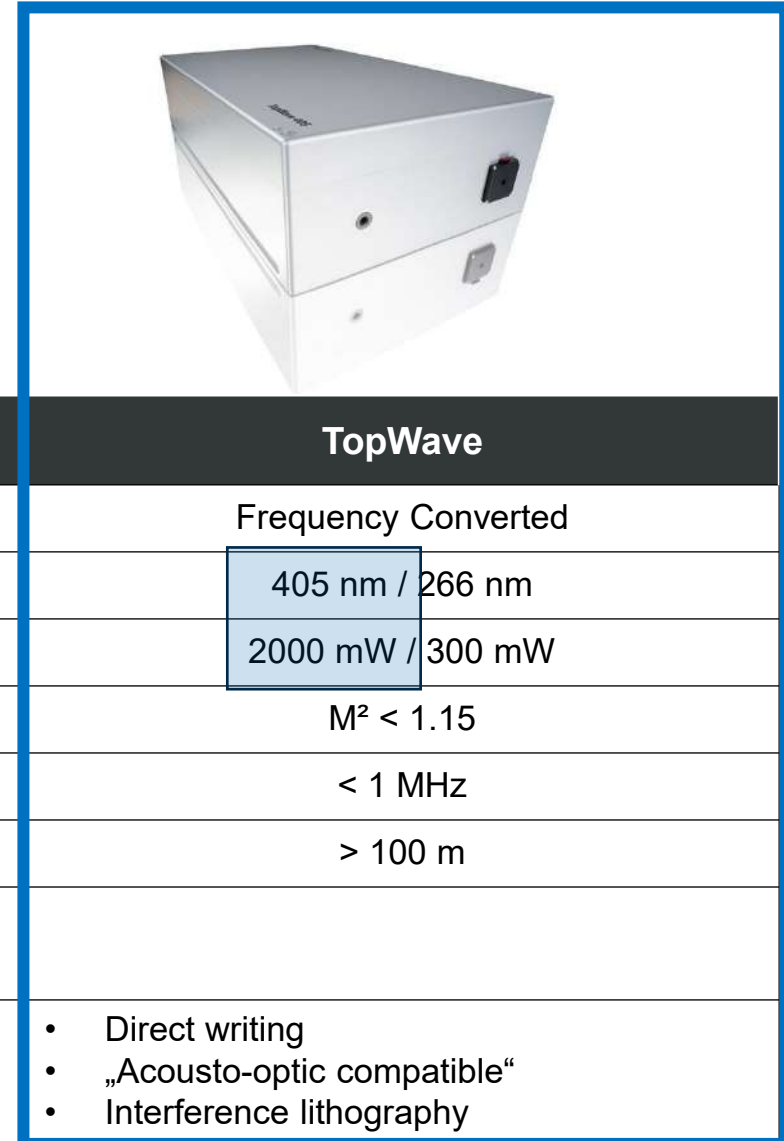

Specification	iBeam smart	TopMode <sup>1)</sup>	TopWave
Type	Direct Diode	ECDL	Frequency Converted
Wavelength	375 nm / <b>405 nm</b>	375 nm / <b>405 nm</b>	405 nm / 266 nm
Output Power	up to <b>400 mW</b>	up to 100 mW	2000 mW / 300 mW
Beam quality	$M^2 < 1.2$	$M^2 < 1.2$	$M^2 < 1.15$
Linewidth FWHM (typ.)	1 nm	< 5 MHz	< 1 MHz
Coherence length (typ.)	< 500 $\mu\text{m}$	> 25 m	> 100 m
Special	<b>Direct high-speed modulation =&gt; no external AOM necessary</b>		
Suited for	Direct writing	<ul style="list-style-type: none"> <li>• Direct writing</li> <li>• „Acousto-optic compatible“</li> <li>• Interference lithography</li> </ul>	<ul style="list-style-type: none"> <li>• Direct writing</li> <li>• „Acousto-optic compatible“</li> <li>• Interference lithography</li> </ul>

<sup>1)</sup> New product generation launching 2026“ (improved characteristics for industrial use cases)

## TopWave 405 - Overview



### High power, solid-state @ 405 nm

- **Up to 2 W**
- Beam quality:  $M^2 < 1.15$  (typ.)
- Beam diameter ( $1/e^2$ ):  $1.5 \pm 0.2$  mm
- Coherence length  $> 100$  m
- Low noise: RIN  $< 0.6$  %
- Lifetime:  $> 10.000$  h (typ.)
- Hands-off operation
- **Highest wall-plug efficiency, low CoO**

# TOPTICA SHG system design

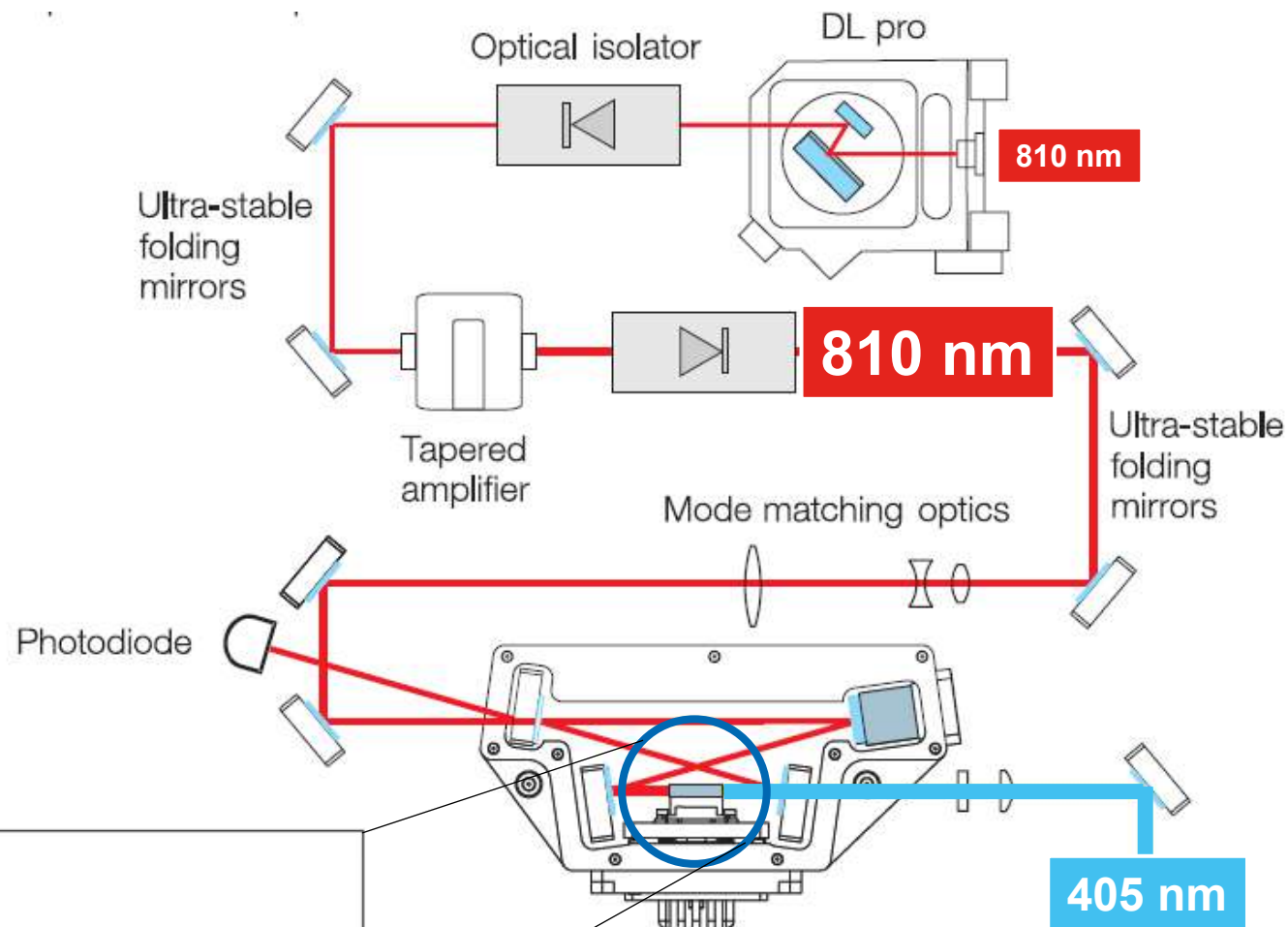

## SHG Operating Principle Second-Harmonic Generation

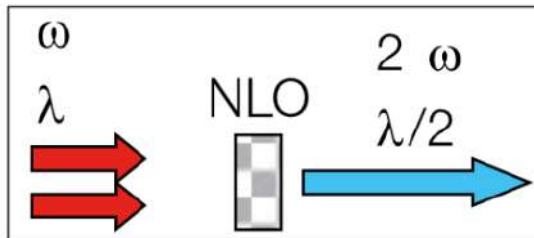

# TopWave 405 – designed for industry use

## Reliability

The TopWave 405 underwent extensive long-term testing. Data for thousands of hours is available for all critical parameters

- Power stability
- Beam pointing
- Beam quality
- Beam diameter
- Beam waist location
- Astigmatism
- Beam Circularity
- SHG wavelength
- ...

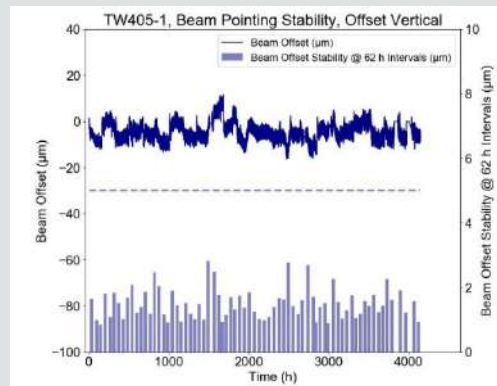
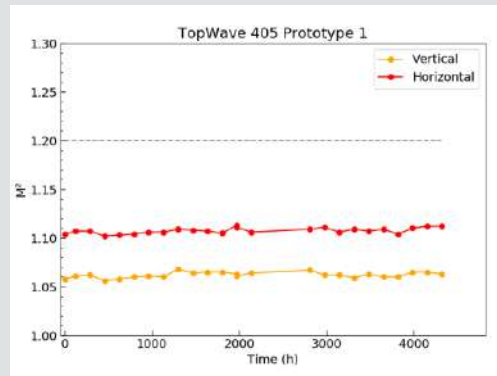

## Ease of use

- **Auto-Align:** automated alignment and optimization of all stages
- **Single Mode Finder (FSMP) & Air Pressure Control**
  - Push-button, fully automated feature
  - Assures excellent wavelength stability and no mode hops, between optimizations
- **Hands-off operation**
  - Full integration into tool control software
  - via GUI

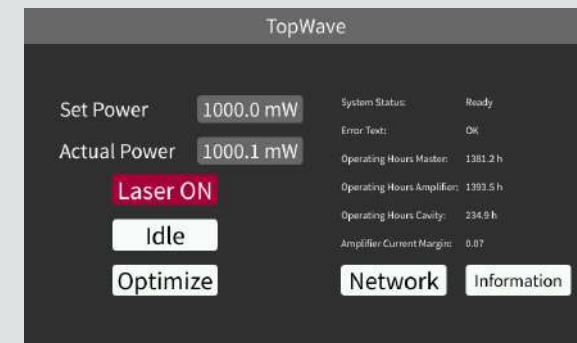

# Summary: TopWave – Industrial Frequency Converted SF-Laser

- Designed for **OEM integration**
- **Consistent** performance **over long lifetime**
- Highest Efficiency -> **low CoO**



**TopWave DUV**

<b>Wavelength</b>	228.5 nm $\pm$ 0.5 nm	257 nm $\pm$ 0.5 nm	<b>266 nm <math>\pm</math> 0.5 nm</b>
<b>Power level</b>	10 mW	15 mW	150 / 300 mW

**TopWave 405**

405 nm $\pm$ 1 nm (other wavelengths e.g. 364 nm on request)
<b>2000 mW</b>

# Agenda

1. TOPTICA – short introduction
2. Photolithography
3. Laser solutions for maskless lithography
  - Overview
  - Example TopWave 405
4. **Sustainability aspects**

# There are still quite a few dinosaurs out there!

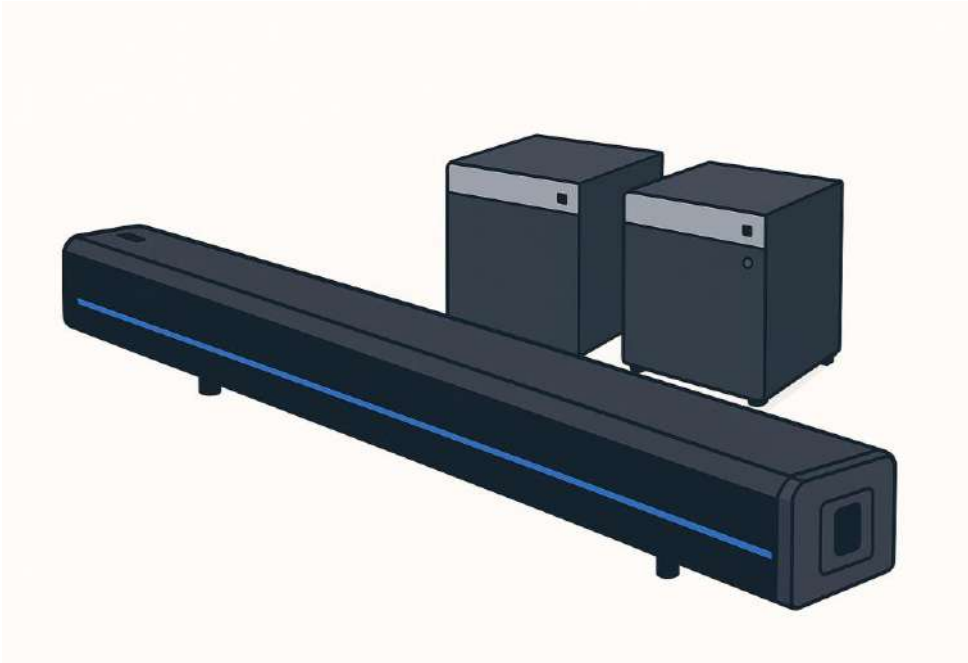

	Typ. Kr+ gas laser	TopWave 405
Electrical	3-phase, 488 VAC 70 Amps per phase	100 .. 240 V~, 50/60 Hz Standard wall outlet
Water	~ 20 liters per min	No plant water necessary
Size laser head (L x W x H)	2170 x 200 x 200 mm <sup>3</sup>	500 x 295 x 127 mm <sup>3</sup>
Size power supply and heat exchanger (L x W x H)	578 x 478 x 508 mm <sup>3</sup> 578 x 478 x 508 mm <sup>3</sup>	348 x 450 x 154 mm <sup>3</sup>
Weight (LH/PS/HE)	109 kg / 107 kg / 75kg	22 kg / 9 kg

- Ion gas lasers are **incredibly inefficient: only < 0.01 %**
- **Annual power consumption** for 24/7 operation corresponds to the consumption of **more than 100 four-person households.**
- Mandatory water cooling
- Bulky and heavy => additional big CO2 footprint during shipping

# Cost of Ownership Comparison

## Solid-state laser (e.g. TopWave 405) vs Kr+ Laser

- Extended maintenance and service intervals
- Low power consumption < 0.1 kW
- Low heat dissipation. No plant water flow necessary

## Typ. lifetime of consumables

Part	TopWave 405	Gas Laser
Seed laser unit	2-3 yrs	N/A
Amplifier unit	2-3 yrs	N/A
SHG unit	2-3 yrs	N/A
Tube	N/A	~ 1 year

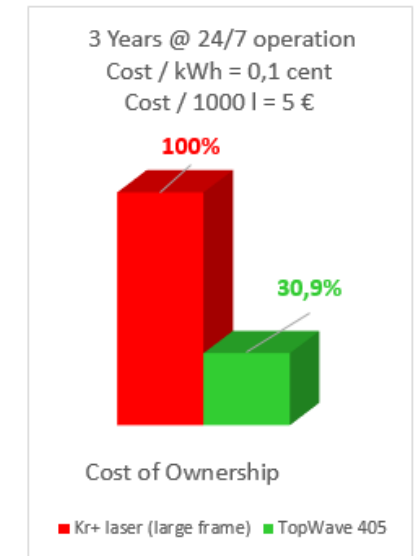
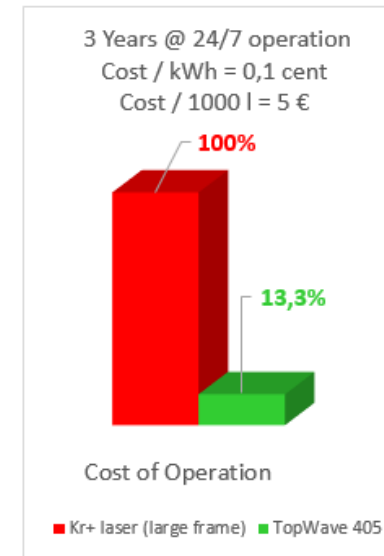
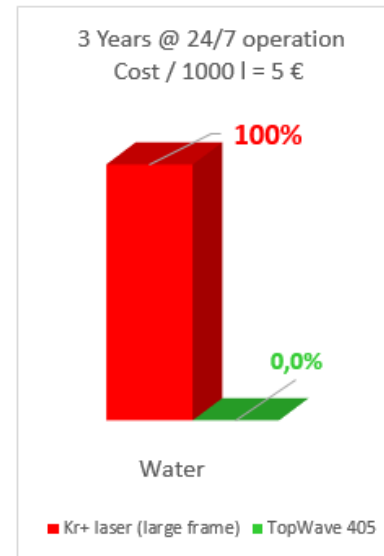
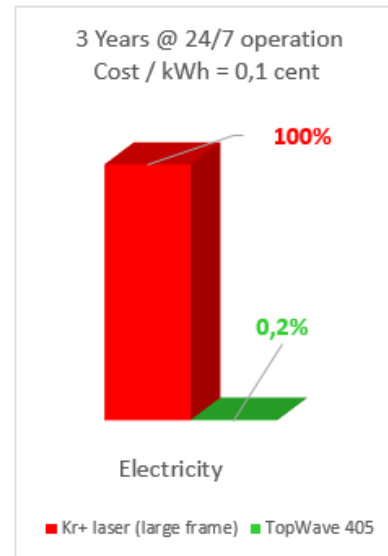
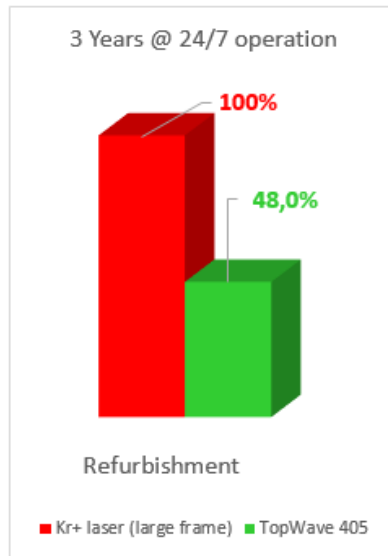

Sample calculation. Actual results may vary.

Thank you for your attention



**all wavelengths.**

190 nm – 0.1 THz